

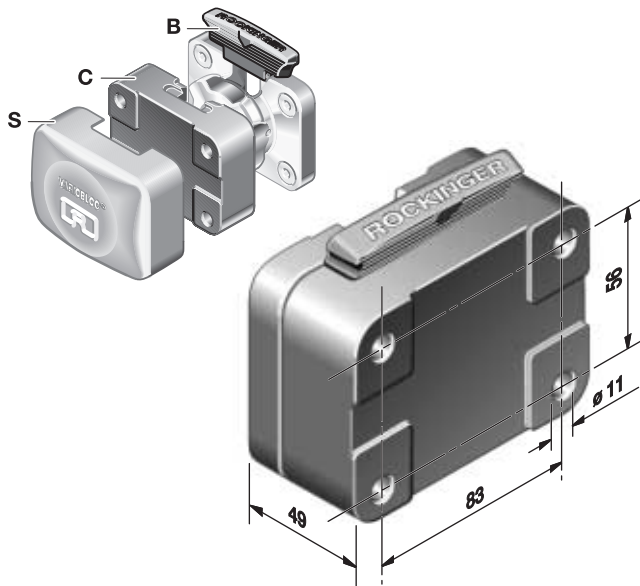

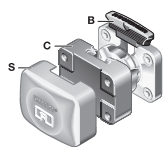



RO★100, VARIOBLOC







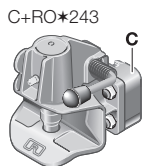

- D** Multifunktionales Wechselsystem für Transporter, Geländewagen, Busse in Verbindung mit Bolzen-, Hakenkuppelung, Kupplungskugel; geeignet für Hecktragesysteme und Arbeitsgeräte.
- GB** Multifunctional alternating system for transporter, cross-country vehicles and buses, in connection with pin hitch, hook trailer hitch, hitch ball, suitable for towbar bracket systems and work devices.
- F** Système mobile multifonction pour véhicules utilitaires, voitures tout terrain et bus liaison avec accouplement à boulon, à crochet ou boule d'attelage ; convient pour systèmes de portage arrière et outillage.
- I** Sistema intercambiabile multifunzione per furgoni, fuoristrada, bus in abbinamento a ganci a perno a uncino e ganci a sfera; adatto per sistemi di trasporto posteriori e attrezzi di lavoro.
- E** Sistema de cambio multifuncional para furgonetas, vehículos todo terreno, autobuses en combinación con enganches de bulón, enganches de gancho, enganches de bola; indicado para sistemas de soporte posterior y útiles de trabajo.

Technische Daten • Technical data • Données technique • Dati tecnici • Datos técnicos







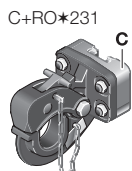

	 (mm)	 D (kN)	 Dc (kN)	 S (kg)	 V (kN)	 (kg)	e1
ROE100A01001	83 x 56	30	30	250	12,0	2,7	00-0044
ROE100A02001	85 x 45	30	18	200	9,6	2,7	00-0044



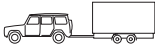



	 (mm)	 D (kN)	 Dc (kN)	 S (kg)	 V (kN)	 (kg)	e1
ROE100C01511	83 x 56	30	18	250	12,0	4,1	00-0031
	83 x 56	30	30	250	8,4	4,1	

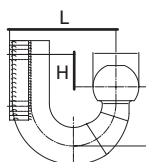
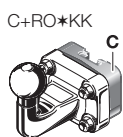

	 (mm)	 D (kN)	 Dc (kN)	 S (kg)	 V (kN)	 (kg)	e1
ROE100C01521	83 x 56	25	22	250	12,0	3,3	



	 (mm)	 D (kN)	 S (kg)	H	L	 (kg)	e1
ROE100C01531	83 x 56	22,5	275	-34	115	3,9	00-2462
ROE100C01541	83 x 56	24,3	300	20	104	3,9	00-2358
ROE100C01551	83 x 56	22,1	270	-90	114	4,2	00-2124
ROE100C01561	83 x 56	19,0	200	-34	133	4,1	00-2462

Ersatzteile • Spare parts • Pièces de rechange • Ricambi • Piezas de recambio

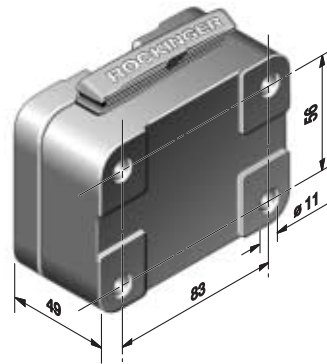
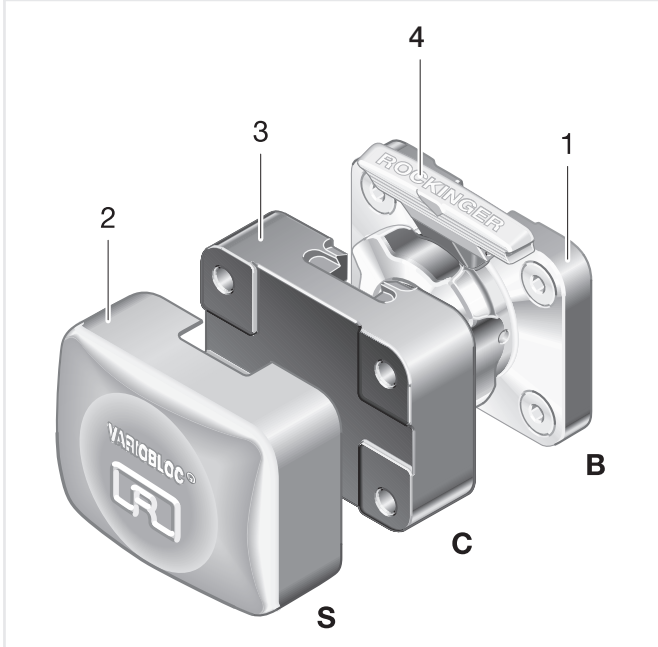

Pos.		ROE	
01	83,0 x 56,0 mm	100B01000	1
01	85,0 x 45,0 mm	100B02000	1
02		25344	1
03	83,0 x 56,0 mm	100C01000	1
03	85,0 x 45,0 mm	100C02000	1
04		70761	1

Befestigungssätze • Screw sets • Kits de fixation • Kit di fissaggio • Juego de elementos de sujeción

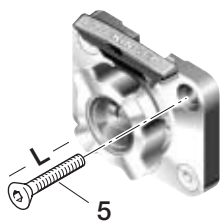

Pos.	L	ROE	
05	40 mm	70759	1
05	50 mm, 30 mm	70756	1
05	55 mm	70570	1
05	60 mm	70558	1
05	110 mm	70754	1
05	130 mm	70805	1

Basisplatte • Base plate on the vehicle
Plaque de base • Piastra base • Placa base

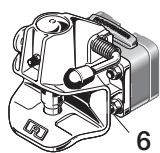

Pos.	L	ROE	
06	50 mm	70755	1

Bolzenkupplung 243 auf Wechselplatte • Pin hitch 243 on the quick-change plate • Accouplement à boulon 243 sur plaque mobile • Gancio a perno 243 su piastra intercambiabile • Enganche de bulón 243 en placa intermedia

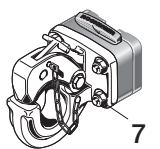

Pos.	L	ROE	
07	50 mm	70755	1

Hakenkupplung 231 auf Wechselplatte • Hook trailer hitch 231 on the quick-change plate • Accouplement à crochet 231 sur plaque mobile • Gancio a uncino 243 su piastra intercambiabile • Enganche de gancho 243 en placa intermedia

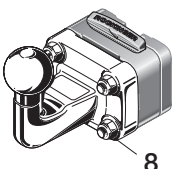

Pos.	L	ROE	
08	50 mm	70755	1
08	60 mm	70757	1
08	65 mm	70758	1

Kupplungskugel auf Wechselplatte • Hitch ball on the quick-change plate • Boule d'attelage sur plaque mobile • Gancio a sfera su piastra intercambiabile • Enganche de bola en placa intermedia

RO★100, VARIOBLOC

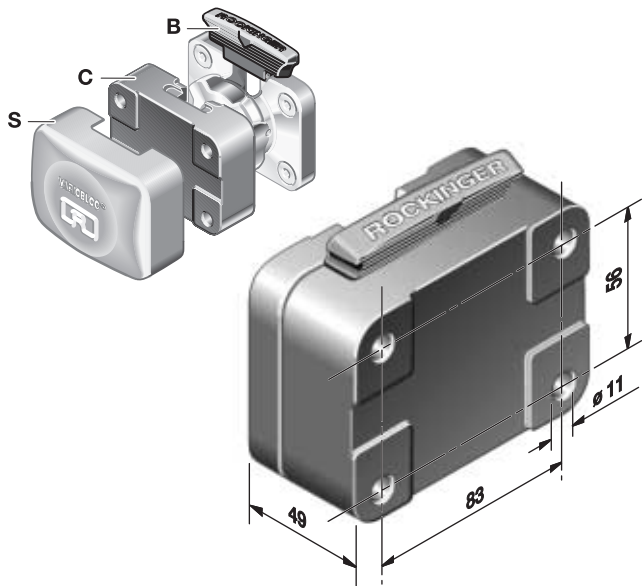

- D** In Verbindung mit Kugelhaken von Fremdherstellern
- GB** In combination with ball hitches from other manufacturers
- F** Pour les crochets à boule d'autres fabricants
- I** Assieme a ganci a sfere di altre case produttrici
- E** En combinación con enganches esféricos de fabricantes ajenos

ISO 83 x 56

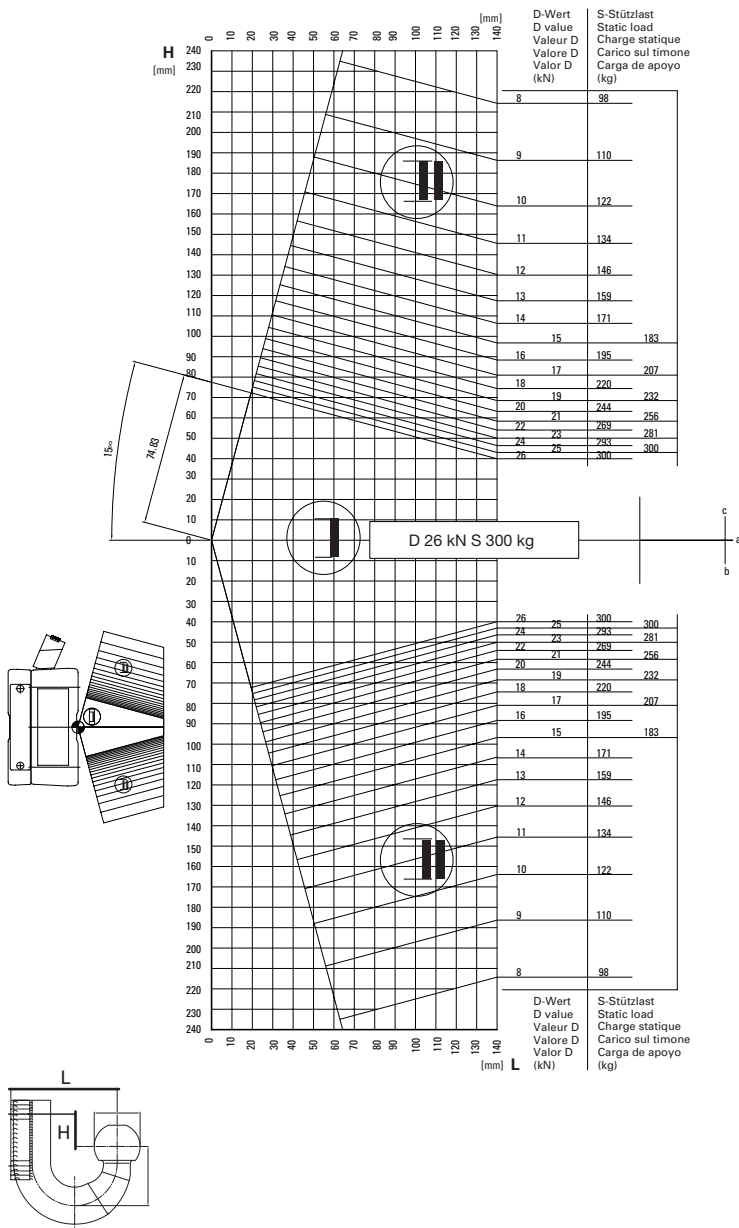

ISO 85 x 45

