

Mounting instructions

Before mounting, both jacks must be in retracted position, in order to take advantage of the total stroke after mounting connection shaft and to avoid premature ground touch of one jack. Otherwise one single jack would have to carry the total load, causing damage.

The jacks must be mounted parallel and properly aligned, otherwise the connection shaft could tilt and make the landing gear hard to operate.

When fitting crank extension JS 2 for telescopic landing gears for two side operation, note different gear box position.

Fitting and bracing should be carried out as shown below.

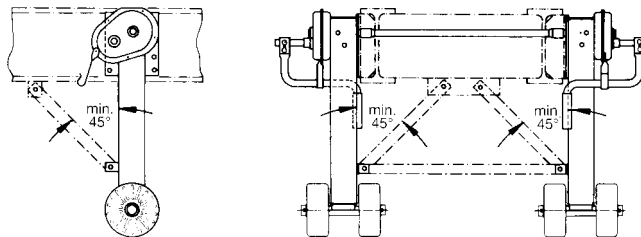

The introduction of air suspension on semi-trailers has resulted in an increase of related problems.

When the semi-trailer has been standing for a considerable time a loss of air in the suspension is liable to occur, causing the rear part of the trailer to sink down.

This in turn results in an angular movement of the axle, forcing the trailer in the direction of travel if the brakes are on. This movement depends on the type of air suspension, the spring deflection and the size of the tyres.

The larger the drift and the greater the force the greater is the chance of the landing gear being subjected to a force with which it cannot cope, ultimately resulting in it being bent. This damage is a secondary consequence of the loss of air.

This can be avoided by using landing gear with drift compensation.

The JOST "A" foot is a semi-wheel which is able to compensate for the entire movement of the trailer and remove the force of drift from the landing gear.

A paved surface is essential for the correct function of this version.

A further variation is the JOST "S" foot. The large sand shoe cannot sink in and can therefore also be used on an unpaved surface.

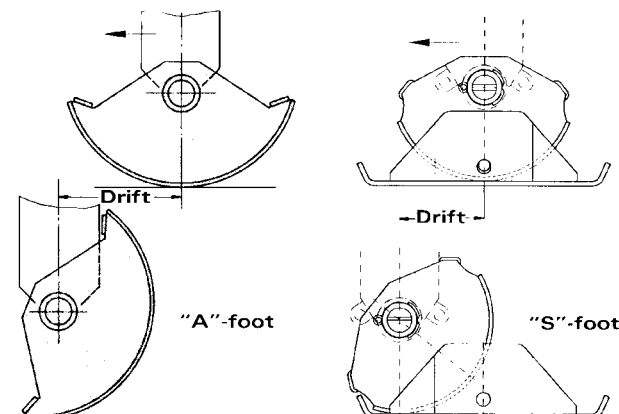

Operating instructions**Uncoupling:**

1. Block wheels of semi-trailer.
2. Unlock and engage crank handle.
3. Wind down landing gear in high gear until ground is touched.
4. Shift to low gear position by pushing the crank handle towards the gear box and lift to necessary height.

Caution: Stop cranking when end of travel is reached.

Coupling-up:

1. After locking the fifth wheel wind-in landing gear in low gear until inner leg has left the ground.
2. Shift to high gear by pulling the crank handle and wind-in inner leg.

Caution: Stop cranking when end of travel is reached.

3. Fasten crank handle in holder, making sure that high gear is still engaged.

Attention:

If landing gear with two side operation is operated by only one person the gears of the non-operated side must be in the neutral position.

Maintenance instructions

The landing gear received adequate initial lubrication during manufacture. Relubrication is possible through grease nipples provided.

The spindle is lubricated with BP grease JS 12 by the lower of the two grease nipples located on the side of the housing. Prior to lubrication wind down the landing leg as far as possible and during lubrication slowly wind it up. For subsequent lubrication of the other greasing points we recommend the use of high pressure grease (EP) with MoS, or graphite additive, for example:

BP L2 1M

BP HT-EP 1

BP JSS2

Esso universal grease M

Shell Retinax AM

When inspecting the trailer, all parts which are subject to wear must be checked and replaced if necessary, at the latest after four years' operation.

These instructions are based on normal conditions of use. In the case of difficult operating conditions the maintenance and lubrication intervals must be reduced accordingly.